



# Central Wisconsin Electric Cooperative



# CWEC Service Area

- CWEC serves 37 townships in 4 counties in Central Wisconsin
- Total members= 8,139

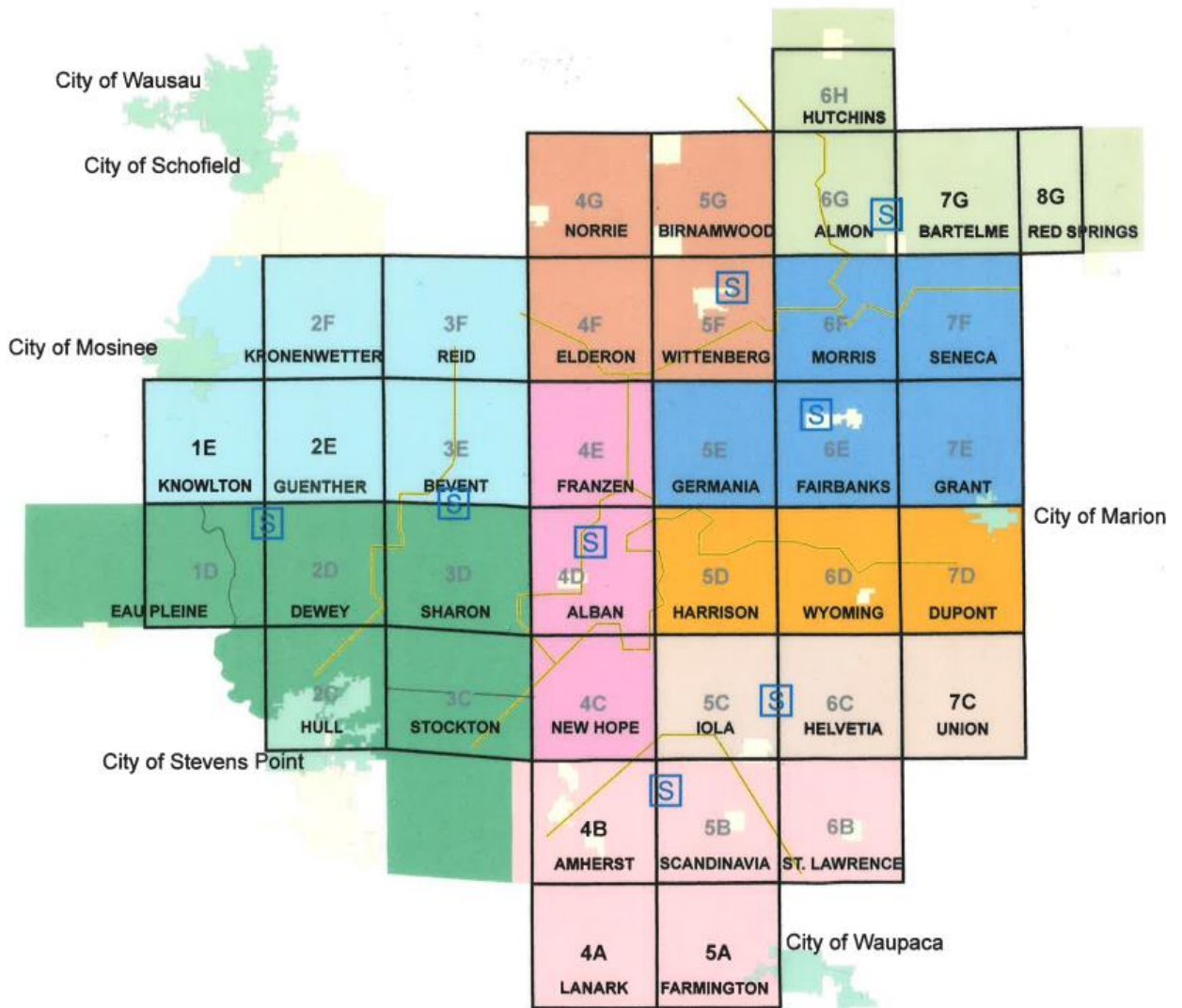

**Updates to this manual may be necessary throughout the year. For the most current information please visit [www.cwecoop.com](http://www.cwecoop.com)**

# CENTRAL WISCONSIN ELECTRIC COOPERATIVE

## WIRING SPECIFICATIONS AND RECOMMENDATIONS

### Table of Contents

	Page
<b>CHAPTER 1 - General Information</b>	2 - 4
Purpose of Service Requirements	
Aim of Service Requirements	
General Information	
Continuity and Quality of Service	
Increased Loads, Service Upgrades, and Relocations	
Continuity and Quality of Service	
Neutral Voltages	
Resale of Energy	
<b>CHAPTER 2 – Services</b>	5 - 28
Types of Services and Voltage Available	
Point of Service	
Service Location	
Clear Working Space	
Meter Sockets	
Wiring for Meters	
Single Meter and Service Requirements	
Yard poles / Meter Poles	
New Electrical Service	
Overhead Secondary Service	
Underground Secondary Service	
<b>CHAPTER 3 – Codes and Requirements</b>	29 - 33
Codes and Requirements	
Grounding at Metering Installations and Service Entrances	
Conduit Requirements	
Capacity, Disconnects, Fault Current Ratings, Ground Fault Protection	
<b>CHAPTER 4 – Equipment on Member Premises</b>	34 - 35
Pulling or Tampering with Meters	
Sealing of Equipment	
Clearances Around Equipment	
Theft of Service	
Resale of Energy	
<b>CHAPTER 5 – Member Generating Equipment</b>	36
Standby Generating Equipment	
Distributed Generation System, Alternate Power and/or Parallel Generation	
<b>CHAPTER 6 – Approved Equipment List</b>	37
Meters	
CT Cabinets	
<b>CHAPTER 7 – Appendix</b>	38 - 39
Clearances	
Field-Built Pedestals	
Transformer pad specifications (750 KVA & Above)	



# **CENTRAL WISCONSIN ELECTRIC COOPERATIVE WIRING SPECIFICATIONS AND RECOMMENDATIONS**

## **Chapter 1 General Information**

### **Purpose of Service Requirements**

The following information is published for the convenience of the members, employees, contractors, architects, engineers, builders, and others concerned with the planning, construction, and operation of electric service installations in the Central Wisconsin Electric Cooperative service area. These requirements are in addition to the Wisconsin Administrative Code, the National Electric Service Code, the National Electric Code and all applicable local, state, and federal regulations. The Cooperative reserves the right to make revisions in these requirements whenever changes in the article, legal requirements, or other circumstances make it advisable.

These requirements are intended for typical electric installations. In the event a situation not covered in this book arises, please consult the Cooperative before proceeding with the installation. The Cooperative management will work to provide a mutually agreeable solution to insure prompt service.

The information contained herein does not specifically cover the requirements of the Cooperative's rate schedules, line extension policy, or Rules and Regulations; the Cooperative should be consulted for information concerning these matters.

The Cooperative may refuse or discontinue service if a member does not comply with these requirements; however, the member will first be notified and afforded reasonable opportunity to comply. Service may be discontinued without prior notice when dangerous conditions exist on the member's premises.

### **Aim of Service Requirements**

Central Wisconsin Electric Cooperative's aim of the service requirements is to provide safe and reliable electric service in accordance with national, state, and Cooperative requirements.

### **General Information**

It shall be the responsibility of the electrical contractor or wiring personnel performing the work to become familiar with the policy, practices, requirements, and rules and regulations of Central Wisconsin Electric Cooperative before undertaking or commencing the work of the installation, repair, relocation, or upgrade of electrical services.

# **CENTRAL WISCONSIN ELECTRIC COOPERATIVE**

## **WIRING SPECIFICATIONS AND RECOMMENDATIONS**

### **Continuity and Quality Service**

The Cooperative will use reasonable care to provide continuous electric service, restore interrupted service quickly, and maintain its facilities and equipment with minimal inconvenience to its members. However, the Cooperative does not guarantee continuous service, standard voltage, or standard frequency at all times. The Cooperative shall not be liable for any loss, injury, or damage resulting from interruptions, deficiencies, or imperfections of service not due to willful default or negligence on its' part.

The Cooperative strongly recommends the member install surge-protection devices for sensitive electronic equipment.

The Cooperative shall have the right to cause service to any customer to be interrupted or limited at any time, without liability, by automatic devices or otherwise, when in the judgment of the Cooperative such interruption or limitation is necessary or desirable due to emergency conditions.

All motors, appliances or equipment connected to the Cooperative's system shall be so designed, installed, and operated as not to cause interference to other members' service equipment nor to impede the Cooperative in maintaining proper system conditions.

It shall be the responsibility of the member to provide motor protection for under voltage, overcurrent, short circuit, and loss of a phase.

The Cooperative may also curtail or temporarily interrupt the member's electric service to make repairs, replacements, or changes to the Cooperative's facilities, either on or off the member's premises. The Cooperative will, whenever practical, give notice to members who might be seriously affected by such suspension or curtailment of service, but shall not be liable for any loss, injury, or damages resulting from interruptions, deficiencies, or imperfections of service not due to willful default or negligence on its' part.

### **Increased Loads, Service Upgrades, and Relocations**

In cases where member's load requirements have changed, necessitating a larger meter, transformer, and / or service conductor size, the Cooperative shall be given reasonable notice so that it may provide equipment of the proper capacity. Risk of delays, poor service or a burned-out meter or transformer will thus be reduced. This applies particularly to members who connect temporary or portable equipment. The Cooperative may charge for the cost of upgrading equipment and / or replacement cost of damaged Cooperative equipment.

## **CENTRAL WISCONSIN ELECTRIC COOPERATIVE WIRING SPECIFICATIONS AND RECOMMENDATIONS**

To determine the impacts on the Cooperative's distribution system, the member shall contact the Cooperative prior to the installation of high demand loads, such as, but not all-inclusive:

- Electric vehicle chargers (Level 2 or 3)
- On demand water heaters
- Single phase motors 10 HP or greater
- Three phase motors 20 HP or greater
- Electric Heat Conversion
- Geothermal Heat Pumps

In cases where member's service needs to be relocated due to additions, grading, and / or other reasons that would make the service inaccessible or in violation of the Cooperative's service requirements or other applicable Codes, the Cooperative shall be given reasonable notice prior to construction to determine what is the best plan of action. The Cooperative may charge for the cost of any relocation work of Cooperative equipment.

# CENTRAL WISCONSIN ELECTRIC COOPERATIVE WIRING SPECIFICATIONS AND RECOMMENDATIONS

## Chapter 2 Services

### **Types of Services and Voltage Available**

The Cooperative shall be consulted as to the type of service available in any area before wiring layouts are made, equipment is purchased, or when extensive wiring changes are contemplated.

The Cooperative furnishes 60-Hertz alternating current, single and three phase, at various voltages. But not all types of service are available in all areas and service extension charges may apply to extend the necessary distribution facilities. The type of service available to the member is ordinarily determined by one or more of the following conditions, but is not all-inclusive:

1. Types of service available at the member's location.
2. Character and size of load to be served.
3. Underground or overhead service.

The Types of Service and Nominal Voltage Furnished. See Rules & Regulations

1. Single-phase, 120/240 volts, three-wire. Size limits apply.
2. Single phase, 240/480 volts, three-wire. Size limits apply.
3. Three-phase 120/208 volts, four-wire Wye. Size limits apply.
4. Three-phase, 277/480 volts, four-wire Wye. Size limits apply.
5. Combination single-phase and three-phase 120/208 volts, four-wire Wye. Size limits apply.

Members' request for additional services or services which do not conform to these requirements shall be treated as "special facilities". The member is obligated, in accordance with Cooperative extension rules, for any added cost involved. The Cooperative reserves the right to deny special facilities.

# CENTRAL WISCONSIN ELECTRIC COOPERATIVE

## WIRING SPECIFICATIONS AND RECOMMENDATIONS

### Point of Service

The energy supplied by Central Wisconsin Electric Cooperative changes ownership at the point of service. This is the location where the member's wiring starts and the Cooperative's ends. In almost all cases the member furnishes and installs the meter socket, service entrance, and conductors, and is responsible for its upkeep and repair. The overhead point of service is where the Cooperative attaches its service drop to the building or structure. The member provides the attachment device. The underground point of service is either at the metering point (self-contained meter or CT cabinet) or the termination box. The Cooperative will own, terminate, and maintain the secondary conductors between transformer and meter socket (or weather head) or the CT cabinet. When conduit or another conductor raceway is required by the Cooperative that will also be supplied and installed by the member to the transformer. **Equipment installed, which has not been approved for use by the Cooperative, will not be connected.**

### Service Location

Meters shall be installed in an accessible location to enable them to be safely read, inspected, tested, and/or disconnected at reasonable times with a minimum of inconvenience to the member and Cooperative. **Indoor services are not approved by CWEC.**

Multiple meter installations served from a single entrance shall be grouped at a location approved by the Cooperative. All single-phase and polyphase meter installations shall be located outdoors.

Meters shall not be installed in patio, porch, deck or carport areas or areas likely to be enclosed. At earth berm buildings that do not have an exposed side suitable for the meter location, the service shall be terminated at a meter pedestal.

Meters shall not be installed on mobile homes.

The meter location shall be on a solid structure free from vibration and possible mechanical damage. The member shall be responsible for providing protection for the meter(s) from damage caused by falling ice, snow, or other objects. In locations where the meter is not protected by roof overhang, the member shall provide a protective shield. A typical ice and snow shield configuration are shown below (Figure 2.1)



# CENTRAL WISCONSIN ELECTRIC COOPERATIVE WIRING SPECIFICATIONS AND RECOMMENDATIONS

**Figure 2.1 Meter Protective Shield**

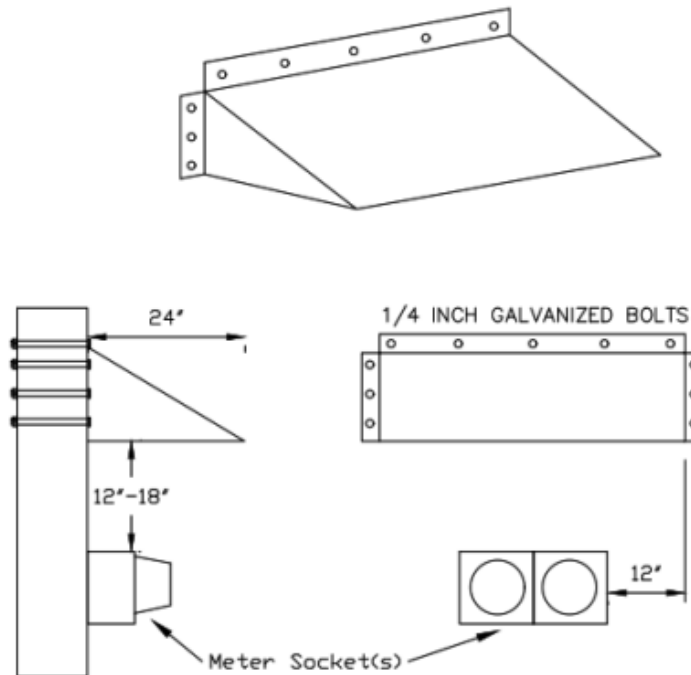

---

## Clear Working Space

The clear working space in front of meter panels must allow CWEC personnel to read and test them without causing a safety hazard to CWEC personnel. **A minimum of 3 feet of frontal clearance is needed.** Depending on the installation, the minimum clearance may need to be increased.

In situations where the service is for an animal confinement operation and, neutral to earth (NEV) (Stray Voltage) is a concern, special restrictions to secondary conductor length apply. See CWEC Rules and Regulations.

If changes are made on the member's premises making the existing meter location unsafe or inaccessible for reading, testing, and/or disconnection the member shall be required to make changes in the wiring so that the meter may be located to comply with these requirements. Failure of the member to correct his wiring within a reasonable length of time after written notification shall be considered as noncompliance with these requirements. The Cooperative reserves the right to discontinue electric service until the member has changed their wiring as outlined above.

# CENTRAL WISCONSIN ELECTRIC COOPERATIVE

## WIRING SPECIFICATIONS AND RECOMMENDATIONS

### **Meter Sockets**

- All meter sockets, meter pedestals, group meter assemblies, and modular meter assemblies shall be listed by an independent testing agency (such as U.L.) for the specified voltage and amperage rating indicated and carry the testing agency's listing mark.
- Meter sockets shall be at a minimum rated 100 Amp capacity for overhead installations and 200 Amp capacity for underground installations.
- An individual self-contained 200 Amp meter socket is the minimum allowed for any new service except approved cases on overhead installations.
- 320 Amp rated services are approved for single and three phase applications.
- All meter sockets shall be ringless
- Meter sockets shall be installed in a level and plumb position securely attached to a solid backing.
- Meter sockets shall have connectors suitable for aluminum or copper conductors
- Corrosion inhibitor shall be used on all connections to aluminum conductors.

Single-phase and three-phase meter sockets shall be installed so that the top of the meter shall be not more than 5 feet 6 inches or less than 4 feet 0 inches above finish grade for overhead services and not more than 5 feet 6 inches or less than 3 feet 0 inches for underground services.

On group installations the meter sockets shall be the following: Bottom meter shall maintain a minimum of 3 feet above the ground. Top meter shall maintain a maximum of 6 feet above the ground. (All measurements are made from the floor/final grade to the top of the electric meter.) Group or ganged sockets shall have a single point of termination for Cooperative conductors.

All residential meter sockets shall be equipped with either an approved horn or lever bypass. CWEC prefers a lever bypass. A horn bypass may not be used in a commercial application.

# **CENTRAL WISCONSIN ELECTRIC COOPERATIVE**

## **WIRING SPECIFICATIONS AND RECOMMENDATIONS**

### **Wiring for Meters**

The Cooperative will under no circumstances permit “Jumpers” to be placed in meter sockets, which results in unbilled energy.

Metered and unmetered conductors shall not be installed in the same conduit or raceway.

On group installations each service switch, breaker, meter pedestal socket or cabinet shall bear a distinctive, permanent marking clearly identifying the location to be served. The location being served shall be identified in the same manner. Labeling shall be included both inside and outside the grouped meter sockets. Inside identification is often done with a permanent black marker or white paint.

The Cooperative shall not permit meters or instruments other than its own to be connected to its meter wiring.

The Cooperative does not allow spliced or tapped conductors inside metering equipment. Exceptions may apply if the equipment manufacturer or UL listing allows. Please contact CWEC engineering for approval.

### **Single Meter and Service Requirements**

The Cooperative will normally supply to each member's building structure or premises:

1. One service lateral (drop)
2. One class of service
3. One meter

The following shall be considered as exceptions to the rule, if allowed by the NEC:

1. Special Conditions – Additional Services shall be permitted to supply the following:
  - a. Fire pumps.
  - b. Emergency systems.
  - c. Legally required standby systems
  - d. Optional standby systems.
  - e. Parallel power production systems.
  - f. Systems designed for connection to multiple sources for the purpose of enhanced reliability.

## **CENTRAL WISCONSIN ELECTRIC COOPERATIVE WIRING SPECIFICATIONS AND RECOMMENDATIONS**

2. Special Occupancies – By special permission, additional services shall be permitted for either of the following:
  - a. Multiple occupancy buildings where there is no available space for service equipment accessible to all occupants.
  - b. A single building or other structure sufficiently large to make two or more services necessary.
  
3. Capacity Requirements – Additional services shall be permitted under any of the following:
  - a. Where the capacity requirements are in excess of 2,000 Amperes at a supply voltage of 600 volts or less.
  - b. Where the load requirements of a single-phase installation are greater than what the serving agency normally supplies through one service.
  - c. By special permission.
  
4. Different Characteristics – Additional services shall be permitted for different voltages, frequencies, or phases, or for different uses, such as for different rate schedules.

For additional references see NEC 230.2; Wisconsin PSC113.0803; and Department of Safety and Professional Services Chapter SPS 316.

### Wisconsin PSC 113.0803 Individual Electric Meters Required for Non-transient Multi-dwelling Unit Residential Buildings, Mobile Home Parks, and for Commercial Establishments

1. Each dwelling in a multi-dwelling unit residential building and mobile home park constructed after March 1, 1980, shall have installed a separate electric meter for each such dwelling unit. Dwelling unit means a structure or that part of a structure which is used as or intended to be used as a home, residence, or a
  
2. Sleeping place by one or more persons maintaining a common household, and shall exclude transient multi-dwelling buildings and mobile home parks; for example, hotels, motels, campgrounds, hospitals, community-based residential facilities, residential care apartment complexes or similar facilities, nursing homes, college dormitories, fraternities, and sororities.
  
3. Each tenant space in a commercial building constructed after March 1, 1980, shall have installed a separate electric meter for each separate tenant space.
  
4. Any existing building which undergoes alterations involving a change in type of occupancy or substantial remodeling shall have installed a separate electric meter for each separate tenant space.

# CENTRAL WISCONSIN ELECTRIC COOPERATIVE

## WIRING SPECIFICATIONS AND RECOMMENDATIONS

### Yard poles / Meter poles

The Cooperative does not allow member wires and equipment to be attached to or supported by the Cooperative poles. For overhead services installations where it is impractical to install the meter on a building, the member shall provide a pole/post to install their service entrance and wiring that will meet all applicable codes. For existing services attached to the Cooperative poles, please consult the Cooperative for upgrades and relocation work.

The Cooperative may set a new pole for the member's use for a fee. This pole is the property of the member and its maintenance is the responsibility of the member.

### New Electrical Service

**For all new electrical services, Central Wisconsin Electric Cooperative requires the member to purchase a free-standing meter pedestal from the Cooperative.** Based on the members' load, the meter pedestal will either be 200A single meter, 200A double meter, or 320A single meter. All free-standing meter pedestals will have the main breaker(s), along with a 20A GFI and three extra breaker spaces for extra/other circuits.

# **CENTRAL WISCONSIN ELECTRIC COOPERATIVE WIRING SPECIFICATIONS AND RECOMMENDATIONS**

## **Overhead Service on Building – 320 Amps or less (see drawing on next page)**

1. Cooperative shall furnish and install conductors to terminate at service mast.
2. Cooperative shall furnish and install connectors to connect the Cooperative's conductors to the Member's conductors.
3. Member shall furnish and install a minimum 100 Amp meter socket approved by the Cooperative. (See Approved Equipment List)
4. Member shall furnish and supply mast, weather head, roof flashing, straps, and conductors. The mast shall be minimum 2" rigid steel conduit or equivalent.
5. Member shall furnish and install load conductors between the meter socket and the service disconnecting means. Service entrance conductors shall not extend over 8 feet into a building unless overcurrent protection is provided at the outer end.
6. Member shall furnish and install two 5/8" X 8' copper clad steel or galvanized ground rods and approved clamps. Ground rods and grounding conductors shall not be installed in front of the meter socket.
7. The grounding electrode conductor from the ground rods shall not be spliced or terminated in the meter socket. The grounding electrode conductor shall be accessible outside of and adjacent to the meter socket for connection of telephone, cable TV, or utility grounding conductors. Ground wire shall meet minimum NEC required electrode conductor size. (Table 250.66 NEC)
8. Member shall furnish and install guy wire and roof attachments as required.
9. Wiring shall be installed in compliance with national electrical code, state electrical code and any local requirements.
10. Meter disconnect points shall be located 5 feet or more in any direction from the discharge outlet of a gas regulator. (Ref. NFPA 58)
11. Expansion sleeves shall be installed on all conduits on service entrance equipment extending below grade.



# CENTRAL WISCONSIN ELECTRIC COOPERATIVE WIRING SPECIFICATIONS AND RECOMMENDATIONS

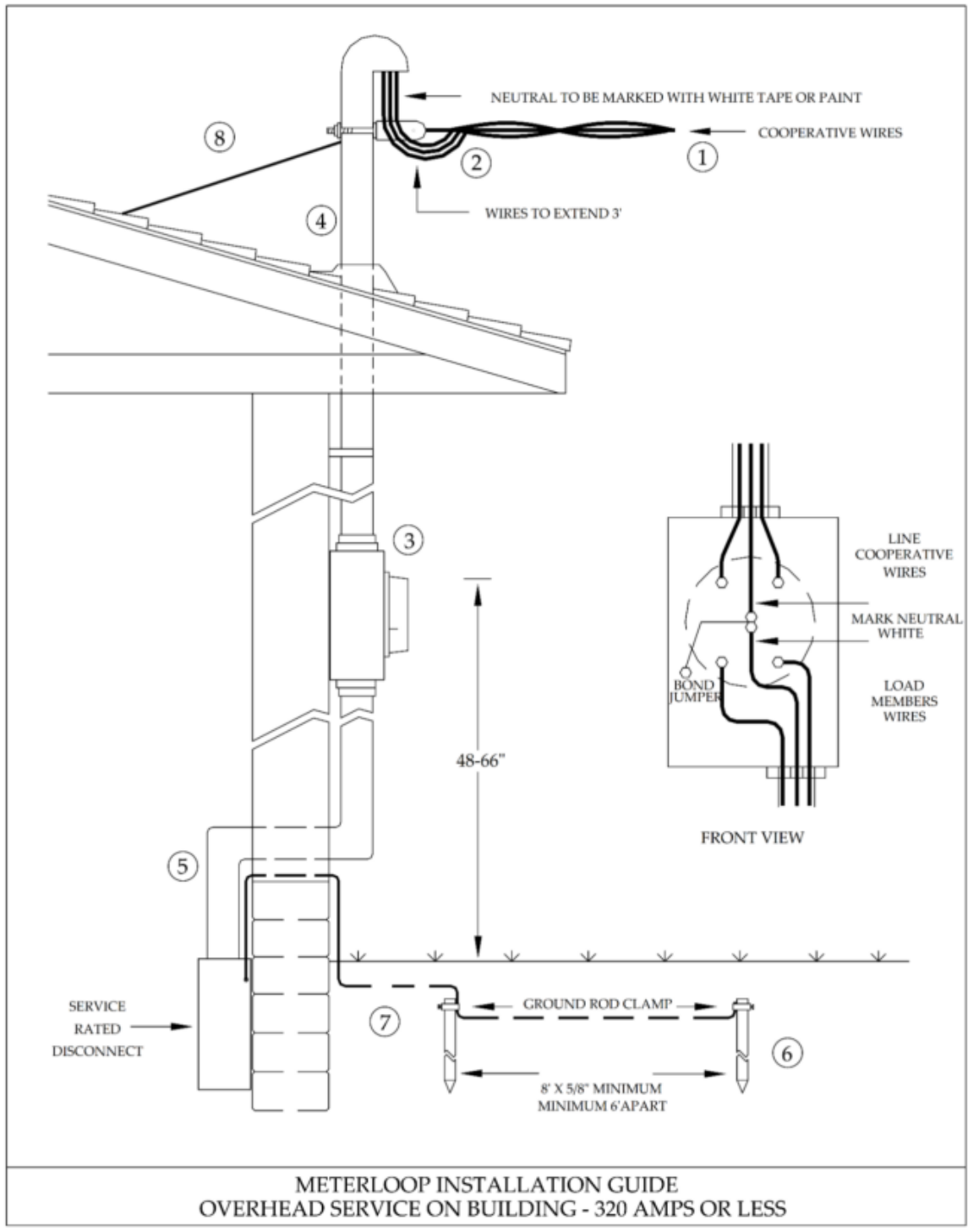

## **CENTRAL WISCONSIN ELECTRIC COOPERATIVE WIRING SPECIFICATIONS AND RECOMMENDATIONS**

### **MEMBER EQUIPMENT IS NOT ALLOWED ON COOPERATIVE POLES**

Contact the Cooperative for upgrades and relocation work to existing services attached to Cooperative poles. (Member may supply a pole or structure to support member service equipment and conductors)

**Pole Top Disconnects are no longer permitted on CWEC system.** Service disconnects will need to be grade level. Contact the Cooperative with questions.

### **Overhead Service on Pole, Underground Load 320 Amp or less (See drawing on next page)**

1. The member shall furnish and install appropriate size pole.
2. Cooperative shall furnish and install conductors to terminate at meter pole.
3. Cooperative shall furnish and install connectors to connect the Cooperative's conductors to the Member's conductors.
4. Member shall furnish and install a minimum 100 Amp meter socket approved by the Cooperative. (See Approved Equipment List)
5. Member shall furnish and install supply side conduit complete with weather head, straps, and conductors. Service entrance (SE) cable shall not be used on pole.
6. Member shall furnish and install a weatherproof disconnecting means, required conduits and conductors. The disconnecting means shall be located on the load side of the meter socket.
7. Member shall furnish and install two 5/8" X 8' copper clad steel or galvanized ground rods and approved clamps. Top of rods should be below final grade level.
8. The grounding electrode conductor from the ground rods shall not be spliced or terminated in the meter socket. The grounding electrode conductor shall be accessible outside of and adjacent to the meter socket for connection of telephone, cable TV, or utility grounding conductors. Top of ground rods should be below grade level. Ground wire shall meet minimum NEC required electrode conductor size (Ref Table 250.66 NEC).
9. Wiring shall be installed in compliance with national electrical code, state electrical code and any local requirements.
10. Meter disconnect points shall be located 5 feet or more in any direction from the discharge outlet of a gas regulator. (Ref. NFPA 58)
11. Expansion sleeves shall be installed on all conduits on service entrance equipment extending below grade.

# CENTRAL WISCONSIN ELECTRIC COOPERATIVE WIRING SPECIFICATIONS AND RECOMMENDATIONS

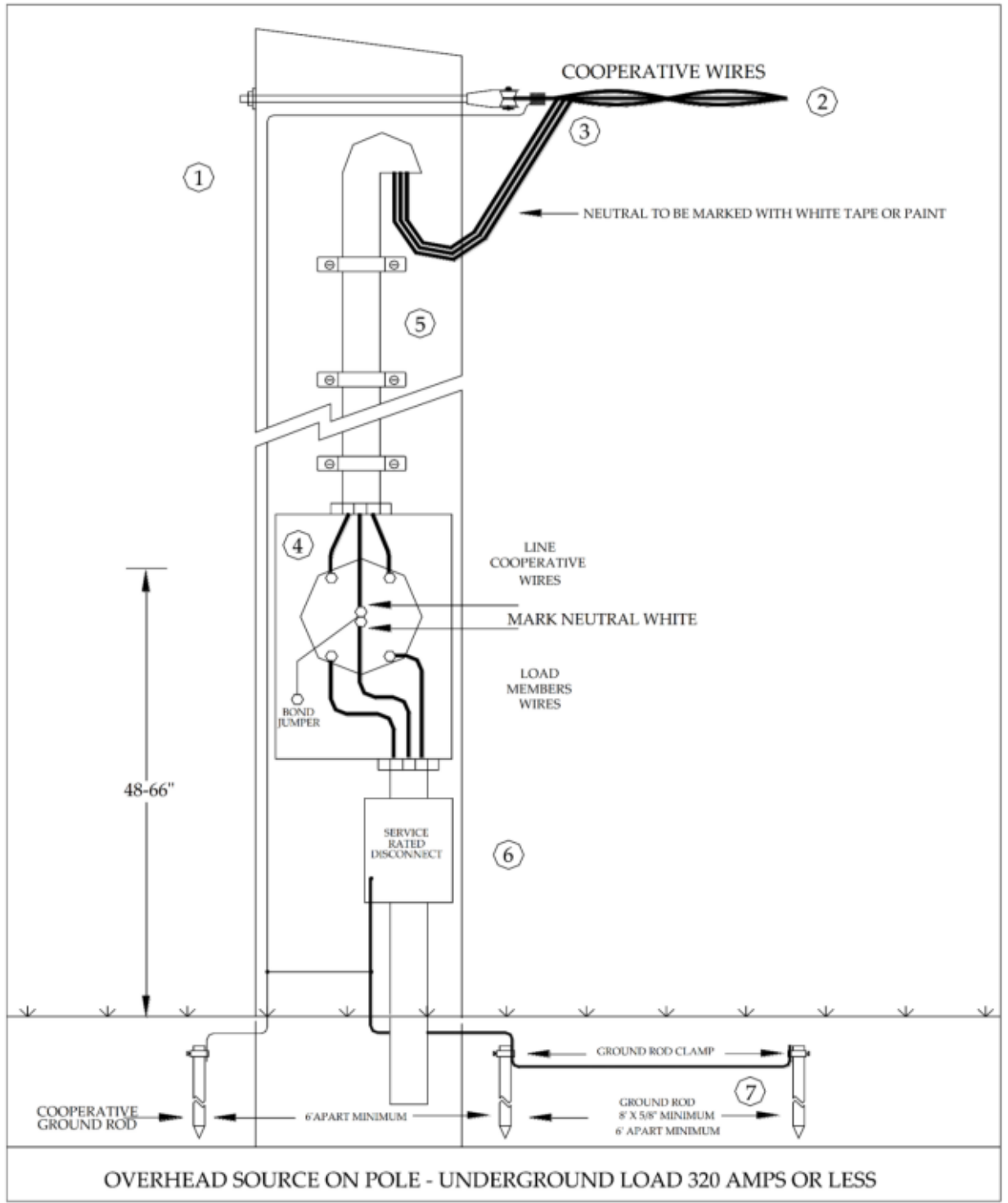

# **CENTRAL WISCONSIN ELECTRIC COOPERATIVE**

## **WIRING SPECIFICATIONS AND RECOMMENDATIONS**

### **Underground Service on Building 320 Amp or less Meter Socket (See drawing on next page)**

1. The Cooperative shall furnish and install the line conductors. Where the Cooperative's wires will be covered by concrete, blacktop, or decks, the member shall be required to provide conduit to extend at least 3 feet beyond the edge of the concrete, blacktop or deck.
2. Member shall furnish and install a minimum 200 Amp meter socket approved by the Cooperative and all required conduit a minimum size of 2 inch for 200 Amp and 2.5 inch for 320 Amp. (See "Approved Equipment List")
3. Member shall furnish and install load conductors between the meter socket and the service disconnecting means.
4. Member shall furnish and install two 5/8" X 8' copper clad steel or galvanized ground rods and approved clamps. Ground rods and grounding conductors shall not be installed in front of the meter socket or within 2 feet of the underground cable route.
5. Expansion sleeves shall be installed on all conduits on service entrance equipment extending below grade.
6. Wiring shall be installed in compliance with national electrical code, state electrical code and any local requirements.
7. Meter disconnect points shall be located 5 feet or more in any direction from the discharge outlet of a gas regulator. (Ref. NFPA 58)
8. The grounding electrode conductor from the ground rods shall not be spliced or terminated in the meter socket. The grounding electrode conductor shall be accessible outside the pedestal for connection of telephone, cable TV, or other utility-grounding conductors. The top of the ground rods should be below grade level. Ground wire shall meet minimum NEC required electrode conductor size (Ref Table 250.66 NEC).

# CENTRAL WISCONSIN ELECTRIC COOPERATIVE WIRING SPECIFICATIONS AND RECOMMENDATIONS

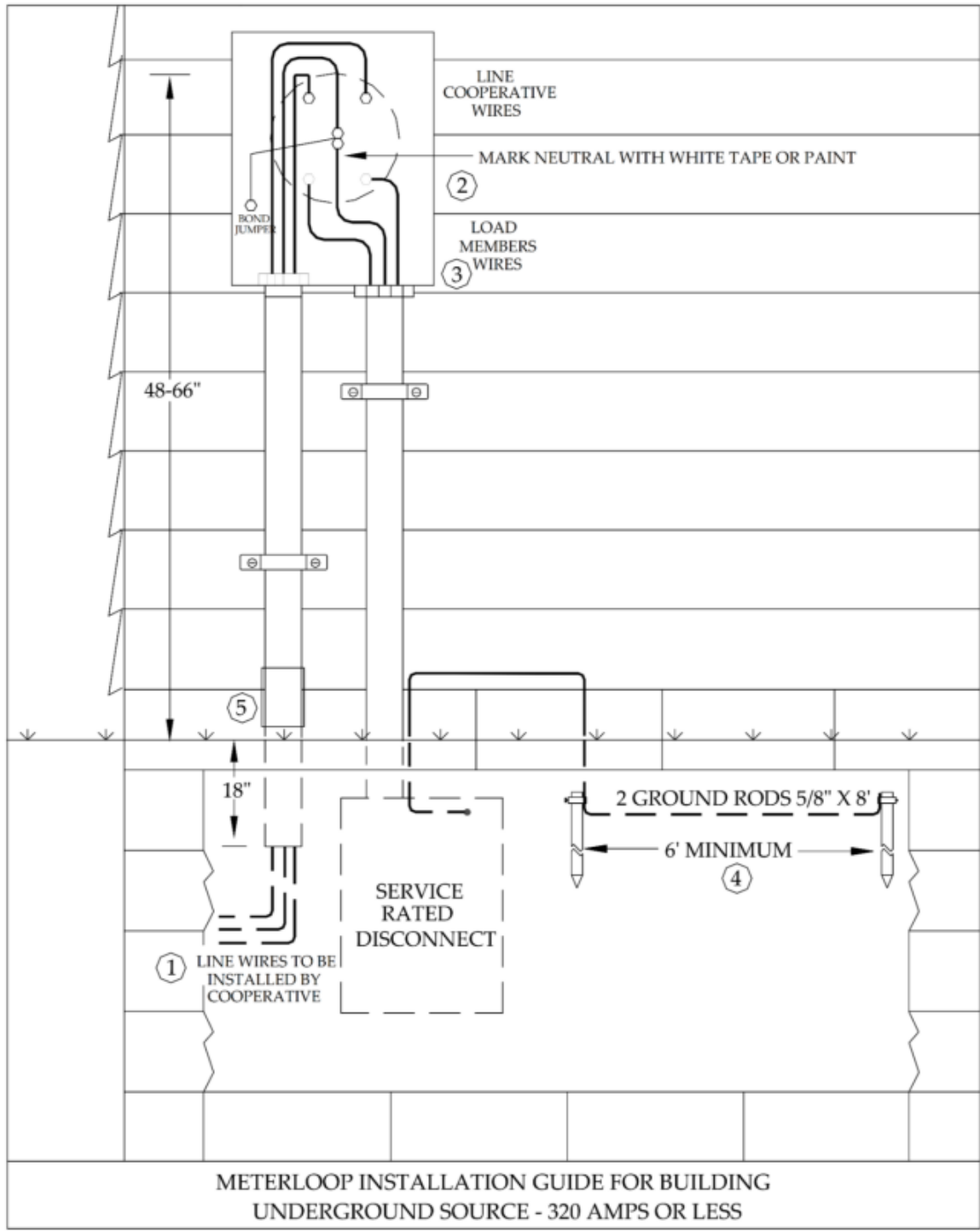

# **CENTRAL WISCONSIN ELECTRIC COOPERATIVE WIRING SPECIFICATIONS AND RECOMMENDATIONS**

## **Underground Service 320 Amp or less Meter Pedestal (See drawing on next page)**

1. The Cooperative shall furnish and install the line conductors. Where the Cooperative's wires will be covered by concrete or blacktop, the member shall be required to provide conduit to extend at least three feet beyond the edge of the concrete, blacktop or decks.
2. Member shall furnish and install a minimum 200-amp meter pedestal approved by the Cooperative. (See "Approved Equipment List")
3. Member shall furnish and install load conductors between the meter pedestal and the service disconnecting means.
4. Member shall furnish and install two 5/8" X 8' copper clad steel or galvanized ground rods and approved clamps. Ground rods and grounding conductors shall not be installed in front of the meter pedestal or within two feet of the underground cable route.
5. The grounding electrode conductor from the ground rods shall not be spliced or terminated in the meter socket or utility portion of the pedestal. The grounding electrode conductor shall be accessible outside the pedestal for connection of telephone, cable TV, or other utility-grounding conductors. The top of the ground rods should be below grade level. Ground wire shall meet minimum NEC required electrode conductor size (Ref Table 250.66 NEC).
6. Adequate space shall be provided for removal of the meter pedestal covers when concrete or blacktop covers the area around the meter pedestal.
7. Member shall furnish and install an extension for the pedestal, if required, to provide a minimum of 18" of pedestal below final grade level.
8. Wiring shall be installed in compliance with national electrical code, state electrical code and any local requirements.
9. No meter pedestal shall be installed under any windows.
10. Meter disconnect points shall be located 5 feet or more in any direction from the discharge outlet of a gas regulator. (Ref. NFPA 58)



# CENTRAL WISCONSIN ELECTRIC COOPERATIVE WIRING SPECIFICATIONS AND RECOMMENDATIONS

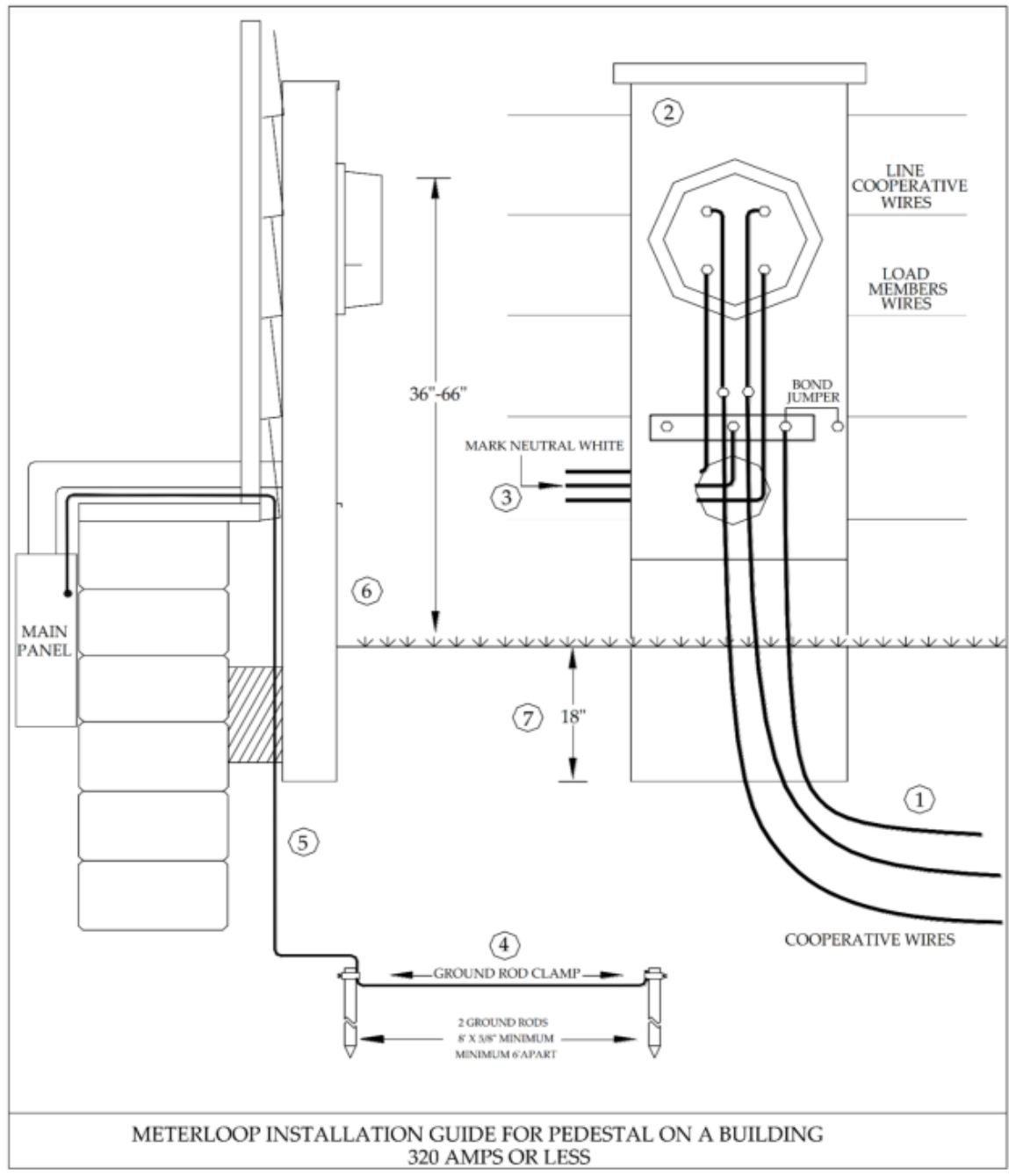

# **CENTRAL WISCONSIN ELECTRIC COOPERATIVE WIRING SPECIFICATIONS AND RECOMMENDATIONS**

## **Underground Service 200 Amp Meter Pedestal (with Main Breaker) (See drawing on next page)**

1. The Cooperative shall furnish and install the line conductors. Where the Cooperative's wires will be covered by concrete or blacktop, the member shall be required to provide conduit to extend at least 3 feet beyond the edge of the concrete, blacktop, or deck.
2. Member shall furnish and install a 200 Amp meter pedestal with main breaker, approved by the Cooperative. (See "Approved Equipment List")
3. Member shall furnish and install load conductors between the meter pedestal and the breaker panel.
4. Member shall furnish and install two 5/8" X 8' copper clad steel or galvanized ground rods and approved clamps. Ground rods and grounding conductors shall not be installed in front of the meter pedestal or within two feet of the underground cable route.
5. The grounding electrode conductor from the ground rods shall not be spliced or terminated in the meter socket or utility portion of the pedestal. The grounding electrode conductor shall be accessible outside the pedestal for connection of telephone, cable TV, or other utility-grounding conductors. The top of the ground rods should be below grade level. Ground wire shall meet minimum NEC required electrode conductor size (Ref Table 250.66 NEC).
6. Adequate space shall be provided for removal of the meter pedestal covers when concrete or blacktop covers the area around the meter pedestal.
7. Member shall furnish and install an extension for the pedestal, if required, to provide a minimum of 18" of pedestal below final grade level.
8. Meter disconnect points shall be located 5 feet or more in any direction from the discharge outlet of a gas regulator. (Ref. NFPA 58)
9. Wiring shall be installed in compliance with national electrical code, state electrical code and any local requirements.

# CENTRAL WISCONSIN ELECTRIC COOPERATIVE WIRING SPECIFICATIONS AND RECOMMENDATIONS

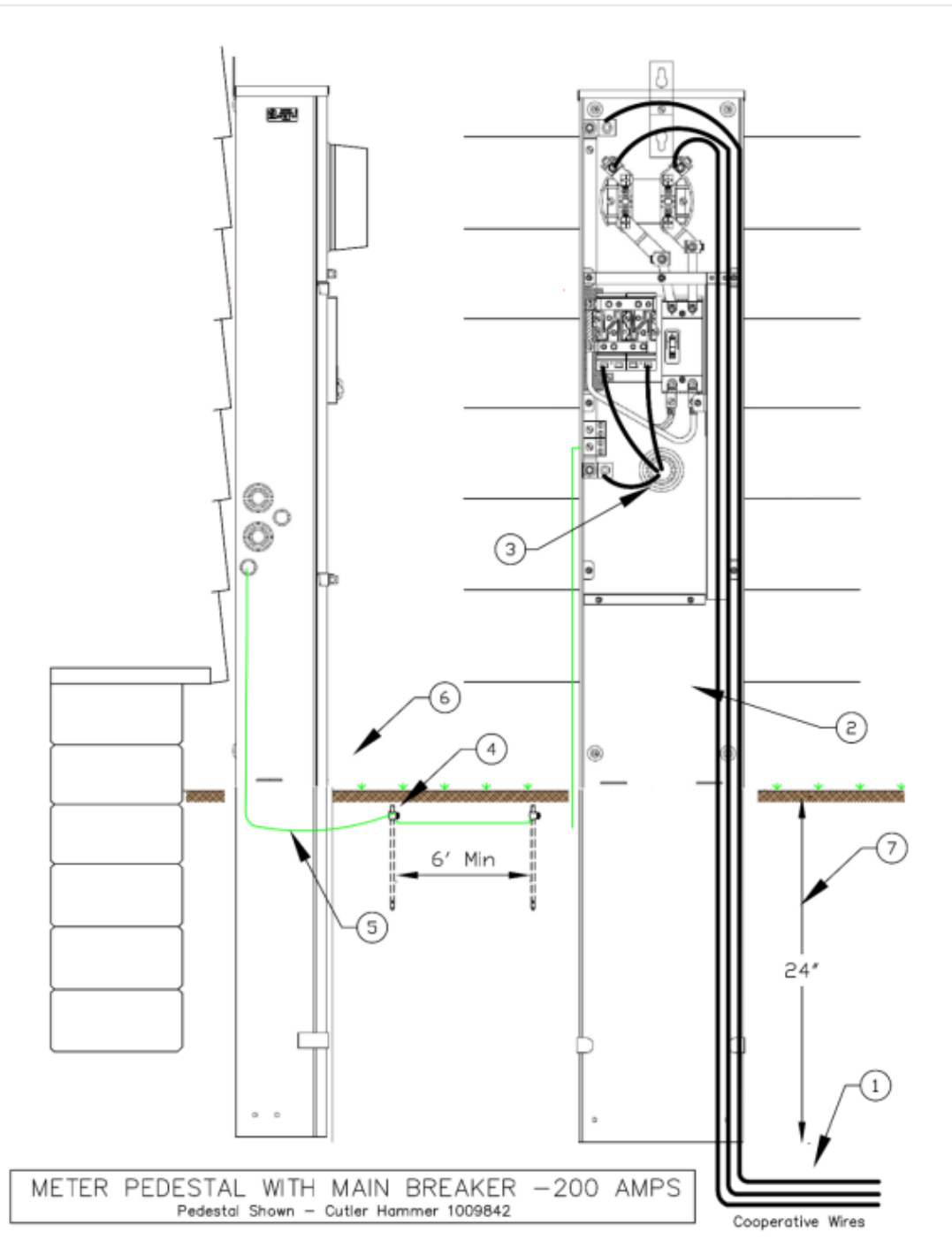

## **CENTRAL WISCONSIN ELECTRIC COOPERATIVE WIRING SPECIFICATIONS AND RECOMMENDATIONS**

### **Free Standing Meter Pedestal with Breakers 320 Amp or less (See drawing on next page)**

1. The Cooperative shall furnish and install the line conductors. Where the Cooperative's wires will be covered by concrete, blacktop or deck, the member shall provide conduit to extend at least 3 feet beyond the edge of the concrete, blacktop, or deck.
2. Member shall furnish and install a minimum 200 Amp meter pedestal approved by the Cooperative (See "Approved Equipment List"). The mobile home service equipment shall be located adjacent to the mobile home, have a three feet separation, and shall not be mounted on the mobile home.
3. Member shall furnish and install a stabilizer foot approved by the Cooperative.
4. Member shall furnish and install the circuit breaker and all connecting conduits and conductors.
5. Member shall furnish and install two 5/8" X 8' copper clad steel or galvanized ground rods and approved clamps. Ground rods and grounding conductors shall not be installed in front of the meter pedestal or within two feet of the underground cable route.
6. The grounding electrode conductor from the ground rods shall not be spliced or terminated in the meter socket or utility portion of the pedestal. The grounding electrode conductor shall be accessible outside the pedestal for connection of telephone, cable TV, or other utility-grounding conductors. Top of ground rods should be below grade level. Ground wire shall meet minimum NEC required electrode conductor size (Ref Table 250.66 NEC).
7. Adequate space shall be provided for removal of the meter pedestal cover when concrete or blacktop covers the area around the meter pedestal.
8. Member shall furnish and install the feeder to the mobile home. The feeder shall consist of 4 insulated conductors of which one shall be an insulated copper equipment grounding conductor. The service equipment or a disconnecting means suitable for service equipment shall be located in sight of and not more than 30 feet from the exterior wall of the mobile home it serves and not mounted on or in the mobile home.
9. Wiring shall be installed in compliance with national electrical code, state electrical code and any local requirements.
10. Meter disconnect points shall be located 5 feet or more in any direction from the discharge outlet of a gas regulator. (Ref. NFPA 58)
11. Omit the additional disconnect if within 30 feet of the mobile home main disconnect.

# CENTRAL WISCONSIN ELECTRIC COOPERATIVE WIRING SPECIFICATIONS AND RECOMMENDATIONS

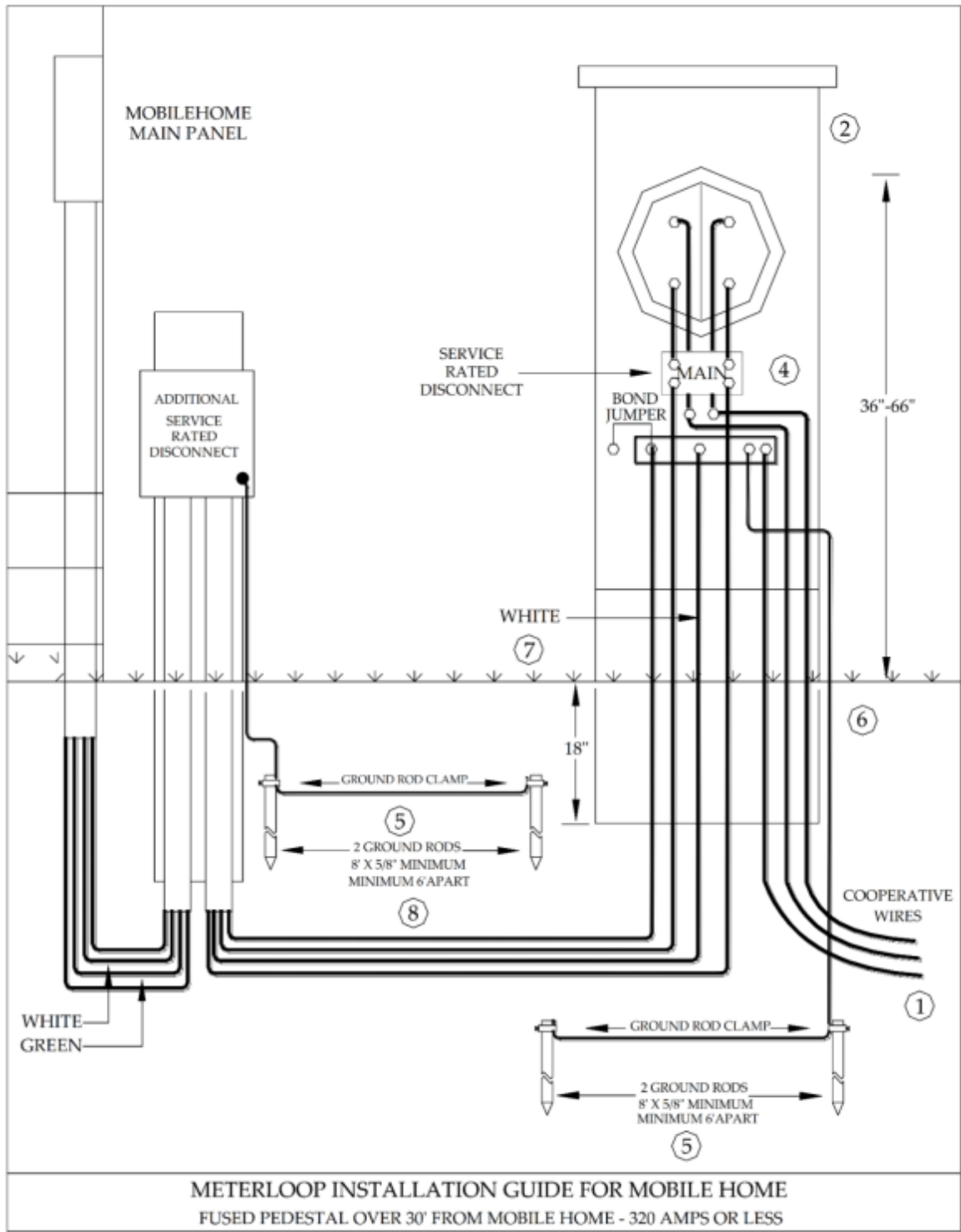

## **CENTRAL WISCONSIN ELECTRIC COOPERATIVE WIRING SPECIFICATIONS AND RECOMMENDATIONS**

### **Underground Service – Without Free Standing Pedestal 320 Amps or less (See drawing on next page)**

1. The Cooperative shall furnish and install the line conductors. Where the Cooperative's wires will be covered by concrete, blacktop or deck, the member shall be required to provide conduit to extend at least three feet beyond the edge of the concrete, blacktop, or deck.
2. Member shall furnish and install a minimum 200 Amp meter socket approved by the Cooperative and all required conduit a minimum size of 2 inch for 200 Amp and 2.5 inch for 320 Amp. (See "Approved Equipment List")
3. Member shall furnish and install treated posts and back board or other support structure approved by the Cooperative. Please refer to Outdoor Free-Standing Meter Structure guide provided in this document on page 41. The mobile home service equipment shall be located adjacent to the mobile home, a three-foot separation and not mounted in or on the mobile home.
4. Member shall furnish and install a weatherproof disconnecting means and all connecting conduits and conductors.
5. Member shall furnish and install two 5/8" X 8' copper clad steel or galvanized ground rods and approved clamps. Ground rods and grounding conductors shall not be installed in front of the meter socket or within two feet of the underground cable route.
6. The grounding electrode conductor from the ground rods shall not be spliced or terminated in the meter socket or utility portion of the pedestal. The grounding electrode conductor shall be accessible outside the pedestal for connection of telephone, cable TV, or other utility-grounding conductors. Top of ground rods should be below grade level. Ground wire shall meet minimum NEC required electrode conductor size (Ref Table 250.66 NEC).
7. Member shall furnish and install the feeder to the mobile home. The feeder shall consist of 4 insulated conductors of which one shall be an insulated copper equipment-grounding conductor. The equipment-grounding conductor shall be minimum 6 AWG insulated copper. The service equipment or a disconnecting means suitable for service equipment shall be located in sight of and not more than 30 feet from the exterior wall of the mobile home it serves and not mounted on or in the mobile home.
8. Expansion sleeves shall be installed on all conduits on service entrance equipment extending below grade.
9. Wiring shall be installed in compliance with national electrical code, state electrical code and any local requirements.
10. Meter disconnect points shall be located 5 feet or more in any direction from the discharge outlet of a gas regulator. (Ref. NFPA 58)



# CENTRAL WISCONSIN ELECTRIC COOPERATIVE WIRING SPECIFICATIONS AND RECOMMENDATIONS

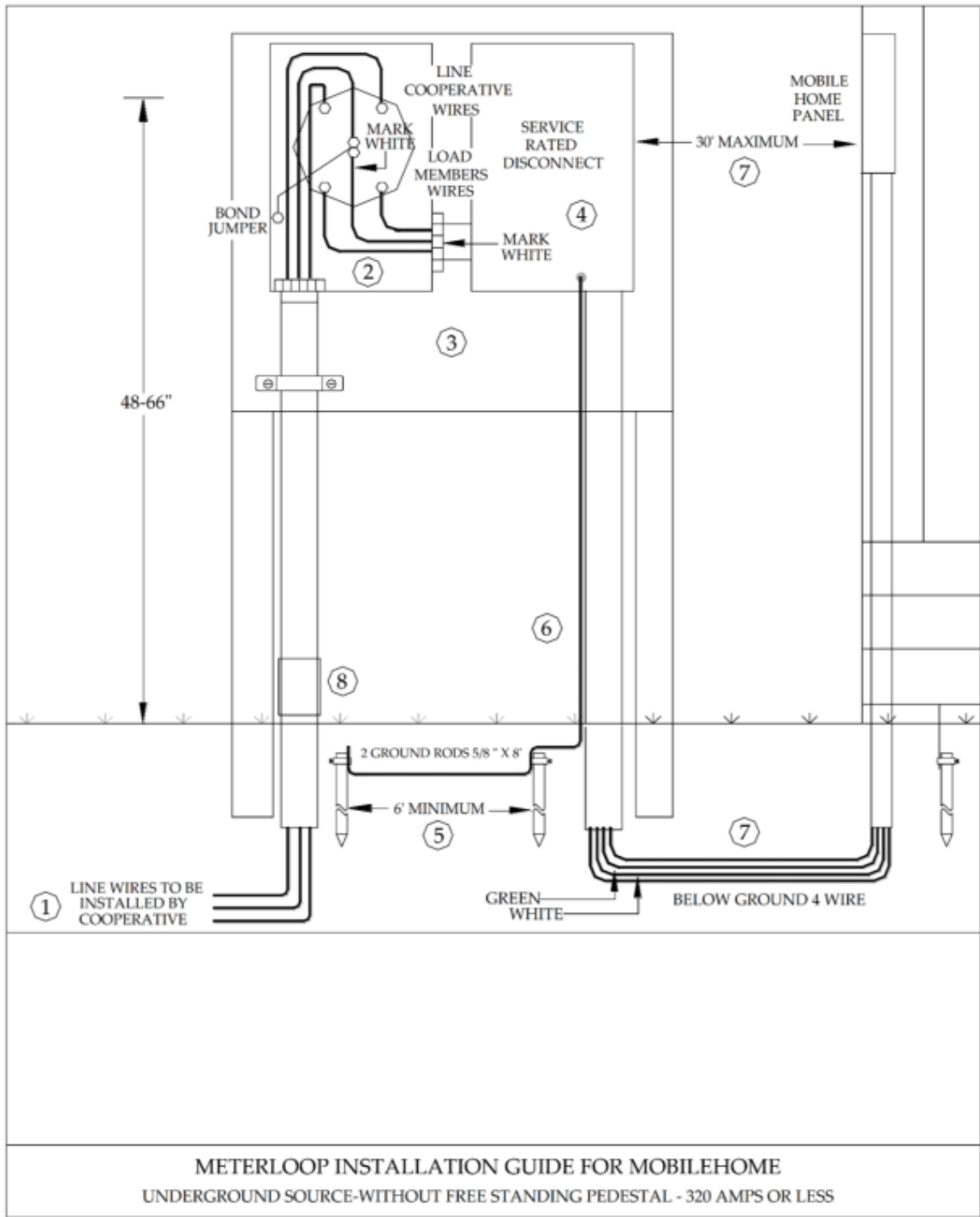

# CENTRAL WISCONSIN ELECTRIC COOPERATIVE

## WIRING SPECIFICATIONS AND RECOMMENDATIONS

### Underground Single and Three phase 400 Amp or larger service

1. Cooperative shall furnish and install current transformers.
2. Cooperative shall furnish and install metering conductors.
3. Cooperative shall install and furnish conductors from the transformer to the CT cabinet.
4. Member shall furnish and install outdoor free-standing structure when not mounted to building. Please refer to page 39 of this document.
5. Member shall furnish and install a Cooperative approved current transformer enclosure and all connecting conduct (See "Approved Equipment List") as required by the Cooperative.
6. Member shall furnish and install rigid steel or schedule 80 PVC to extend a minimum of 18" below finished grade along with expansion sleeves for frost heave. (See page 31 for conduit requirements).
7. Member shall furnish and install meter socket: Single phase- U7487-RL-TG-KK plus 5T8K2. Three Phase- UC7449-XL. Must have a minimum 1" connecting conduit. These terminals shall be the bolt- in type. No push-in terminals allowed. **METER SOCKETS SHALL NOT BE INSTALLED ON THE DOOR OF CT CABINET.**
8. Member shall furnish and install double throw switch (required if standby generator is used) and service equipment, as required.
9. Member shall furnish and install load conductors and connectors on the load side.
10. Member shall furnish and install grounding conductor and conduit per NEC
11. Member shall furnish and install two 5/8" X 8' copper clad steel or galvanized ground rods and approved clamps. Ground wire shall meet minimum NEC required electrode conductor size (Ref Table 250.66 NEC).
12. Member shall furnish and install Equipment Bonding Conductor between CT cabinet and meter socket. (Ref Table 250.102 NEC)
13. Member shall furnish and install the Bonding Jumper conductor from the neutral buss bar to the CT enclosure per NEC.
14. Expansion sleeves shall be installed on all conduits on service entrance equipment extending below grade.

**CENTRAL WISCONSIN ELECTRIC COOPERATIVE  
WIRING SPECIFICATIONS AND RECOMMENDATIONS**

**Single Phase CT Cabinet**

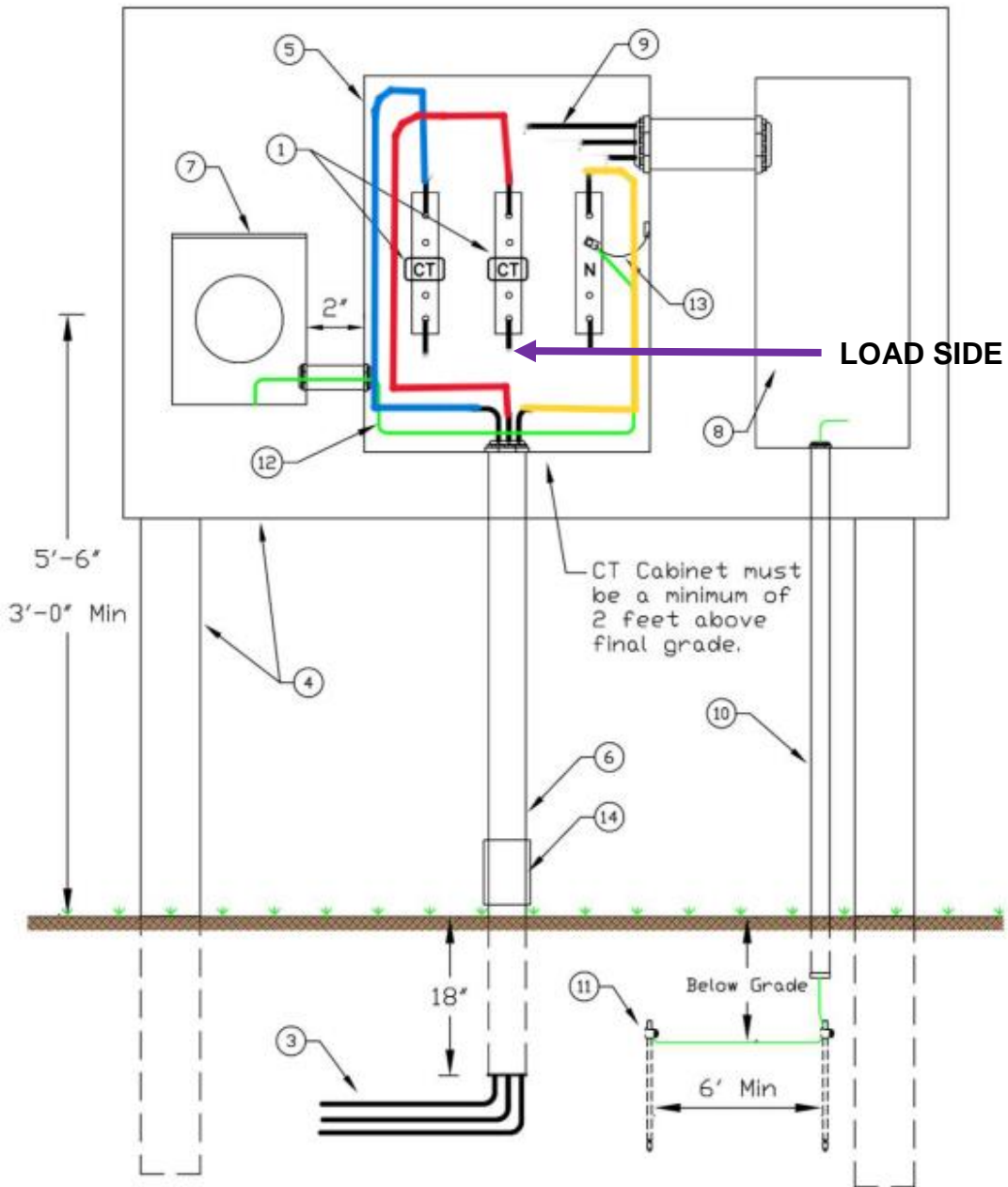

# CENTRAL WISCONSIN ELECTRIC COOPERATIVE WIRING SPECIFICATIONS AND RECOMMENDATIONS

## Three Phase CT Cabinet

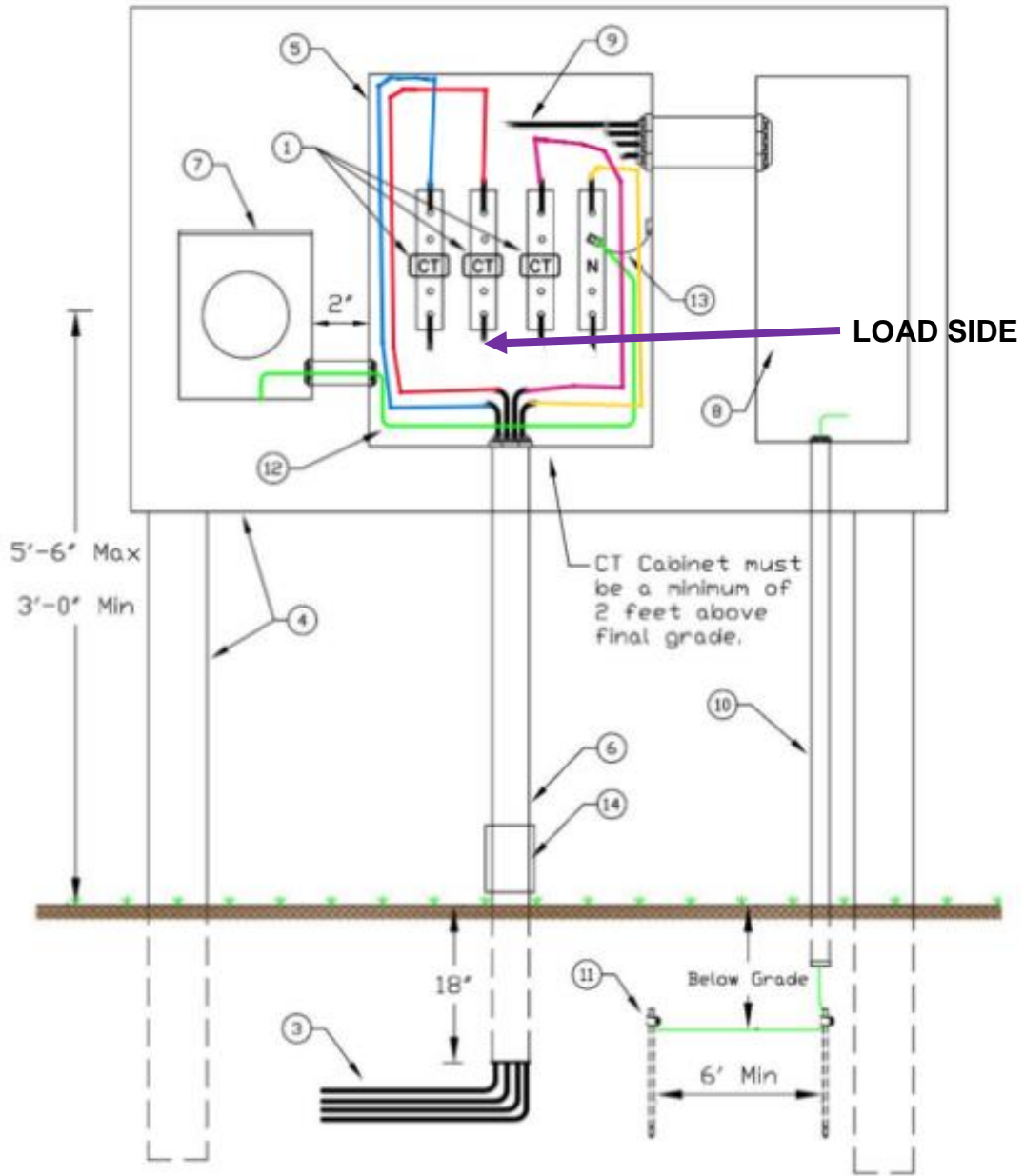

# CENTRAL WISCONSIN ELECTRIC COOPERATIVE WIRING SPECIFICATIONS AND RECOMMENDATIONS

## Chapter 3 Codes and Requirements

### Codes and Requirements

All wiring installations must conform to the minimum requirements by the following governing authorities:

- Central Wisconsin Electric Cooperative's electric service requirements
- Local ordinances
- State and National Codes
- National Electrical Code
- National Electrical Safety Code
- National Fuel and Gas Code (NFPA 54)
- Liquefied Petroleum Gas Code (NFPA 58)
- Wis. Dept. of Transportation

State law requires that the Cooperative must receive an authorized electrical inspector's certificate of approval or, if there is no local inspector, a wiring affidavit form stating that the wiring complies with all applicable codes involving the electrical installation. The Cooperative is not required to inspect wiring installations or equipment as to safety, suitability, or compliance with codes and will not inspect member's wiring and equipment beyond the meter pedestal or cabinet for compliance with the applicable codes. The Cooperative does reserve the right to refuse to connect a service, or to disconnect an energized service, that in its sole judgment appears to be unsafe or in violation of code.

The Cooperative will not interpret the electrical code. Questions concerning code interpretations should be referred to the local or state electrical inspectors.

The Cooperative will inspect for compliance with its requirements and may refuse or discontinue electric service if its requirements are not complied with.

Service may be obtained prior to completion of wiring if the service entrance is completed and compliance with Cooperative requirements and proof of compliance with applicable codes has been received.

Cooperative crews setting meters or connecting new services for single-phase one family dwellings test for infinite resistance at the meter socket load terminals. If this check indicates connected load at the load terminals, the meter will not be set. It is recommended that the service disconnect switch be left open to avoid the indication of connected load at the meter base.

# **CENTRAL WISCONSIN ELECTRIC COOPERATIVE WIRING SPECIFICATIONS AND RECOMMENDATIONS**

## **Grounding at Metering Installations and Service Entrances**

The grounding electrode conductors from the ground rods shall not be installed in the conduit with Cooperative service conductors, nor can it be spliced or terminated in the meter socket, or in the utility side of the meter pedestal.

Grounding systems for all electrical service entrances shall meet electrical code requirements of 2 ground rods installed at least 6 feet apart.

Ground rods and grounding electrode conductors shall not be located in front of meter pedestals, wire troughs or within 2 feet of underground cable route.

## **Rigid Conduit**

“Rigid Conduit” includes rigid galvanized steel, rigid aluminum, galvanized IMC or rigid nonmetallic conduit schedule #80 PVC electrically rated and schedule #80 equivalent polyethylene. The rigid nonmetallic conduit shall conform to specifications in Articles 342, 344, 352 of the National Electric Code. “Galvanized steel conduit” may be either rigid steel or galvanized intermediate metal conduit (IMC). It shall not be electric metallic tubing (EMT).

The tables below are a general guide to determine the conduit sizes and number for the services listed. The sizes and number of these facilities may have to be modified to consider the length of the lateral, customer, load, and voltage drop considerations.



# CENTRAL WISCONSIN ELECTRIC COOPERATIVE WIRING SPECIFICATIONS AND RECOMMENDATIONS

## UNDERGROUND SECONDARY SINGLE-PHASE CONDUIT

Main Service Disconnect Amperes	Minimum Number of Conduits	Conduit Size	Minimum Bend Radius Galvanized Steel	Minimum Bend Radius Rigid Non-Metallic
200	1	2"	9.5"	18"
320	1	2.5"	13"	24"
400	2	4"	16"	30"
600	3	4"	16"	30"
800*	3	4"	16"	30"

\*Contact CWEC for larger than 600 amperes.

## UNDERGROUND SECONDARY THREE PHASE CONDUIT

Main Service Disconnect Amperes	Minimum Number of Conduits	Conduit Size	Minimum Bend Radius Galvanized Steel	Minimum Bend Radius Rigid Non-Metallic
200	1	2.5"	13"	24"
320	1	4"	13"	24"
400	2	4"	16"	30"
600	3	4"	16"	30"
800	3	4"	16"	30"
1200	5	4"	16"	30"
1600	4	5"	24"	36"
2000	5	5"	24"	36"
2500	7	5"	24"	36"
3000	8	5"	24"	36"

Notes: (For both the Single Phase and Three Phase Tables)

1. Conduit is required for any services that run under concrete, asphalt, and any other flatwork
2. All PVC Conduit elbows shall be pre-formed
3. For longer conduit runs containing 3 or more bends, the electrician or member shall consult with CWEC for conduit size, and for the radius bend to use
4. Application – Use Schedule 80 PVC when entering or exiting grade, Schedule 40 PVC may be used below grade or above grade

# CENTRAL WISCONSIN ELECTRIC COOPERATIVE

## WIRING SPECIFICATIONS AND RECOMMENDATIONS

### Capacity, Disconnects, Fault Current Ratings, and Ground Fault Protection

#### Determination of Minimum Fault Current Ratings for Member's Disconnects and Breakers

The Minimum Fault Current Rating is not determined by the size of the member's service, rather, it is a property of the transformer that the service is connected to.

#### Single Phase

To determine the Minimum Fault Current Rating for a Single-Phase transformer, use the following formula:

$$MFC = \frac{kva * 1000}{v * \%Z} \quad \text{where}$$

MFCR = Minimum Fault Current Rating

kVA = kVA of the transformer

V = Line to line voltage of the secondary of the transformer

%Z = Impedance of the transformer taken from the nameplate

Example: 25kVA, pad-mount, 12470GY/7200V, 240/120V with 2.11% Impedance

$$MFC = \frac{25 * 1000}{240 * .0211}$$
$$MFC = 4937 \text{ Amp}$$

#### Three Phase

To determine the Minimum Fault Current Rating for a Three-Phase transformer, use the following formula:

$$MFC = \frac{kVA * 1000}{V * 1.732 * \%Z} \quad \text{where}$$

MFCR= Minimum Fault Current Rating

kVA = kVA of the transformer

V = Line to line voltage of the secondary of the transformer

%Z = Impedance of the transformer taken from the nameplate

Example: 75KVA, pad-mount, 12470GY/7200V, 480Y/277V with 3.51% Impedance

$$MFC = \frac{75 * 1000}{480 * 1.732 * .0351}$$

$$MFC = 2570 \text{ Amps}$$

---

## **CENTRAL WISCONSIN ELECTRIC COOPERATIVE WIRING SPECIFICATIONS AND RECOMMENDATIONS**

### Comm 16.25(5) – Wisconsin Rule in Addition to NEC 230.7

Disconnecting means shall be provided to disconnect the utility wiring from the premises wiring at any point where utility wiring terminates, and premises wiring extends overhead or underground to more than one building or structure.

For member installations of two to six breakers, or sets of fuses, on the load side of a termination box, or current transformer cabinet, the sum of the ratings of the circuit breakers, or fuses shall be permitted to exceed the rating of the termination box or instrument transformer cabinet provided the load is calculated in accordance with NEC Article 220. That load shall not exceed the ampacity rating of the termination box or current transformer cabinet. The NEC article 220 load calculations shall be provided in writing to Central Wisconsin Electric Cooperative. The rating of the service disconnect is to be not less than the calculated load to be carried and not the actual load carried. (NEC 230.79)

The member shall provide the Cooperative with all load information and the proposed service entrance size and voltage requirements.

# CENTRAL WISCONSIN ELECTRIC COOPERATIVE WIRING SPECIFICATIONS AND RECOMMENDATIONS

## Chapter 4 Equipment on Member Premises

### **Pulling or Tampering with Meters**

Meters and meter equipment are sealed by the Cooperative for the purpose of protecting the metering equipment and the member consumer. Removing and replacing meters can be dangerous and shall be done only by the Cooperative's authorized personnel. **Only CWEC personnel are authorized to install and remove the electrical meter.** Violators will be held responsible for metering errors, damage to the equipment and any personal injuries resulting from improper handling of said equipment. **ANY TAMPERING OF CWEC EQUIPMENT WILL RESULT IN \$500 FINE, AND COULD BE SUBJECT TO CRIMINAL PROSECUTION BY LOCAL AUTHORITITES.**

If you must have the power disconnected, please contact the Cooperative for assistance.

### **Sealing of Equipment**

Meters and all associated metering equipment, service termination boxes, wire raceway, and service entrance switches containing unmetered conductors are sealed by the Cooperative. This equipment must be designed with provisions for seals or locks as specified by the Cooperative.

Unauthorized removing of Cooperative seals is unlawful and may result in a billing for the investigation and replacement of the seal as well as criminal prosecution.

### **Clearances Around Equipment**

There should be no brush, branches, trees, bushes 10 feet or less in front of cabinets and transformers. Adequate clearance of at least 5 feet to all other sides should be maintained.

# CENTRAL WISCONSIN ELECTRIC COOPERATIVE WIRING SPECIFICATIONS AND RECOMMENDATIONS

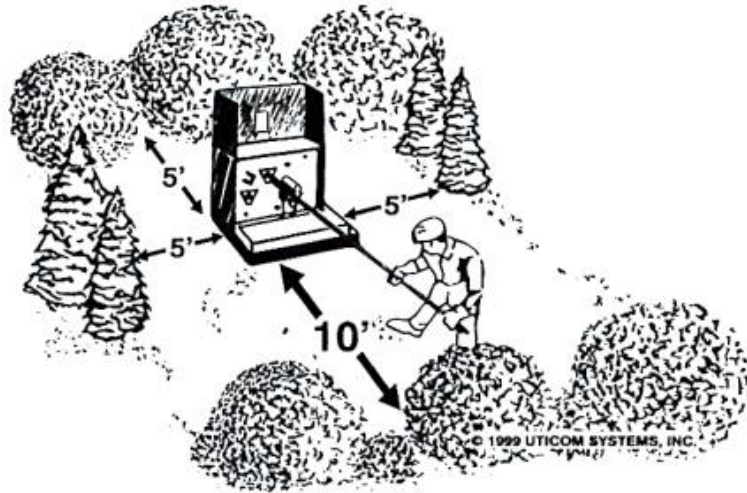

## **Theft of Service**

The Cooperative will investigate for the possibility of theft of service whenever tampering with meter seals, meters, service conductors, and service connections is reported or detected. Only Cooperative authorized persons are permitted to make connections to Cooperative lines.

If the investigation determines that electricity is being stolen, the service will be disconnected.

Prior to restoration of service the member's service entrance equipment shall be made tamper resistant in accordance with Cooperative requirements and satisfactory arrangements will have been made for payment of the estimated amount of unmetered electricity and all other associated cost with the theft of service.

The Cooperative will pursue criminal prosecution for all cases of theft of service.

## **Resale of Energy**

Service shall be for the member's use only and may not be sold, re-metered or otherwise disposed of by the member to lessee, tenants, or others, except with the consent of the Cooperative in accordance with the Cooperative's appropriate Rate Schedule permitting such use of service. This does not prohibit the installation of test or check meters for informational purposes.

Including an estimate of the cost of electric service in the rent without identification as such is permitted.

# **CENTRAL WISCONSIN ELECTRIC COOPERATIVE WIRING SPECIFICATIONS AND RECOMMENDATIONS**

## **CHAPTER 5 Member Generating Equipment**

### **Standby Generating Equipment**

The Cooperative shall be consulted before any generating equipment is connected to any circuits which are or may be supplied from Cooperative's service lines.

The member shall install an approved double pole / double throw service-rated (transfer) switch that is mechanically interlocked – (of adequate current and voltage rating) so that the connected member's generating equipment cannot energize the Cooperative's supply lines.

The double pole / double-throw (transfer) switch may be manually or automatically operated. Member-owned generating equipment shall not operate in parallel with the Cooperative's system except under specific contract with the Cooperative covering the conditions of such operation.

### **Distributed Energy Resource**

A parallel generation system allows the transfer of electrical energy from the member's generator in the Cooperative's distribution system. Consult the Cooperative for the requirements of this service.

# CENTRAL WISCONSIN ELECTRIC COOPERATIVE WIRING SPECIFICATIONS AND RECOMMENDATIONS

## Chapter 6 Approved Equipment List

**CWEC approves all sockets/pedestals that are UL listed and within rated size specifications.**

Contact CWEC if approval of sockets is questionable. Add 5<sup>th</sup> terminal on sockets used for CT metering and network metering.

# CENTRAL WISCONSIN ELECTRIC COOPERATIVE WIRING SPECIFICATIONS AND RECOMMENDATIONS

## Chapter 7 Diagrams

### **Overhead Conductor Clearances (Secondary)**

Triplex wire vertical clearances (0-750 volts) to:

RR Tracks 24ft.

Roads, Streets, Alleys 16ft.

Driveways, Parking Lots 16ft.

Land that could have vehicular traffic 16ft.

Land with restricted traffic 12ft.

Water, ponds, streams, etc. From 14ft. to 37.5ft. (consult inspector)

Swimming Pools 22.5ft.

Roofs within 6' of mast 18"

Roofs more than 6' from mast 3'

Roof crossing not attached to mast 3.5'

Signs, chimneys, antennas 3.5'

These are minimum clearances for low voltage lines only. Contact your local Cooperative for assistance and more detailed information. See also Wisconsin State Electrical Code Chapter PSC 114.

### **Outdoor location of pad mount transformers near buildings**

All pad mounted transformers will be located a minimum of 10 feet from any building wall unless a proper fireproof barricade is installed. (Wisconsin Administrative Code PSC 114)

### **Outdoor free-standing meter structure guide (H-Structure) (See designs below)**

1. Field Built Pedestals: 1200 Amp Maximum

2. Wood field-built pedestals shall have a minimum of two 4"x6" or 6"x6" wood posts and 2"x 6" planks that are commercially treated against decay. The posts shall be buried a minimum of 4' deep and plumb. Adding concrete to the full depth provides a stronger foundation but is not required. The planks shall be level and fastened with galvanized hardware (lag screws (minimum 3") or bolts). **CWEC prefers everything to be bolted, but is not required.** The standard width of the structure is 24 to 60 inches. Contact CWEC if larger structure is needed.

3. All service equipment shall be waterproof, lockable, and listed by an approved testing agency for service entrance use.

4. Galvanized Steel and Unistrut may be substituted, after confirming design with the Cooperative.



# CENTRAL WISCONSIN ELECTRIC COOPERATIVE WIRING SPECIFICATIONS AND RECOMMENDATIONS

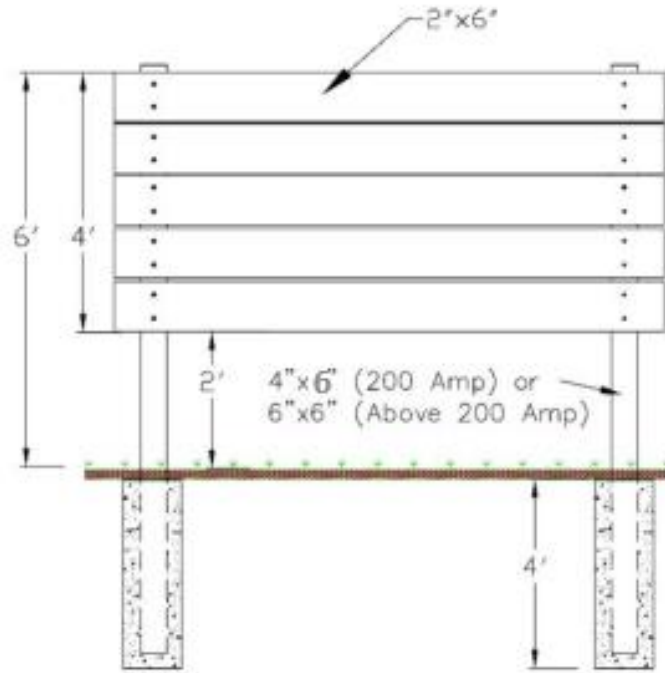

Wood Construction

Steel / Unistrut  
Construction

